

SensaGuard™ Rectangular Flat Pack Unique Coding 440N-Z21US2*

Installation Instructions

Original instructions in English



Allen-Bradley



IMPORTANT

SAVE THESE INSTRUCTIONS FOR FUTURE USE.

ENGLISH:	This instruction sheet is available in multiple languages at www.rockwellautomation.com/literature . Select publication language and type "SensaGuard" in the search field.
GERMAN:	Dieses Instruktionsblatt kann in mehreren Sprachen unter www.rockwellautomation.com/literature gelesen werden. Bitte Ihre Sprache anwählen und "SensaGuard" im Suchfeld eintippen.
FRENCH:	Ces instructions sont disponibles dans différentes langues à l'adresse suivante www.rockwellautomation.com/literature . Sélectionner la langue puis taper "SensaGuard" dans le champ de recherche.
ITALIAN:	La presente scheda d'istruzione è disponibile in varie lingue sul sito www.rockwellautomation.com/literature . Selezionare la lingua desiderata e digitare "SensaGuard" nel campo di ricerca.
SPANISH:	Puede encontrar esta hoja de instrucciones en varios idiomas en www.rockwellautomation.com/literature . Seleccione el idioma de publicación y escriba "SensaGuard" en el campo de búsqueda.
PORTUGUESE:	Esta folha de instruções está disponível em várias línguas em www.rockwellautomation.com/literature . Seleccione a língua de publicação e entre com "SensaGuard" no espaço de busca.
POLISH:	Ta kartka z instrukcjami jest dostępna w wielu językach na stronie: www.rockwellautomation.com/literature . Wybierz język publikacji i wpisz w polu poszukiwania "SensaGuard".

Installation Instructions

Installation must be in accordance with the following steps and stated specifications and should be carried out by suitable competent personnel. The unit is not to be used as a mechanical stop. Guard stops and guides must be fitted. Adherence to the recommended maintenance instructions forms part of the warranty.

This device is intended to be part of the safety related control system of a machine. Before installation, a risk assessment should be performed to determine whether the specifications of this device are suitable for all foreseeable operational and environmental characteristics of the machine to which it is to be fitted. Refer to Technical Specifications below for certification information and ratings.

ATTENTION



The presence of spare actuators compromise the integrity of the safety systems. Personal injury or death, property damage or economic loss can result. Appropriate management controls, working procedures and alternative protective measures should be introduced to control their use and availability.

WARNING



Do not defeat, tamper, remove or bypass this unit. Severe injury to personnel could result. The sensor **MUST** be connected to a Class 2 SELV 24V DC, +10%/-15% power supply.

Technical Specifications

Safety Classification	Type 4 Interlocking Device per ISO 14119 (High Coding) PLe, Cat 4 per ISO 13849-1 SIL CL3 per IEC 62061 and IEC 61508
Standards	CSA 22.2 No. 14, ISO 13849-1, ISO 14119, IEC 60947-5-3, IEC 61508, IEC 62061, and UL508
Certifications	TÜV, CE Marked for all applicable directives, cULus
Functional Safety Data	PFH _D : 1.12 · 10 ⁻⁹

Operating Characteristics

Sensing Distance

Assured Make	15 mm
Assured OFF	35 mm
Typical Misalignment	(±7 mm in both axes)
Repeat Accuracy	10% of sensing range
Max. output current (all outputs)	200 mA
Input Current	50 mA (no load supply current)
Operational Current, Min.	≥1 mA DC
Off-state Current	<0.5 mA DC
Max. no. of switches, connected in series	Unlimited. See Unit Response Time section on page 5.
Operating Voltage	24V DC +10%/-15%; Class 2 SELV power supply
Frequency of operating cycle	1 Hz
Response Time (Off)	54 ms first switch; 18 ms for each additional switch
Case Material	Valox® DR 48
Actuator Material	Valox® DR 48

Outputs (guard door closed, actuator in place)

Outputs	Description	Status
Safety	2 x PNP, 0.2 A max.	ON (+24V DC)
Auxiliary	1 x PNP, 0.2 A max.	OFF (0V DC)

Protection

Short-circuit	Incorporated
Current Limitation	Incorporated
Overload	Incorporated
False Pulse	Incorporated
Transient Noise	Incorporated
Reverse Polarity	Incorporated
Overvoltage	Incorporated
Thermal Shutdown/Restart	Incorporated
Electrical Life	10 x 10 ⁶

Environmental

Operating Temperature [C (F)]	-10...+55° (14...131°)
Operating Humidity	5...95% relative
Washdown Rating	NEMA 3, 4X, 12, 13, IP69k
Shock & Vibration	IEC 68-2-27 30 g, 11 ms/IEC 68-2-6 10...55 Hz
Radio Frequency	IEC 61000-4-3 IEC 61000-4-6

Dimensions [mm (in.)]

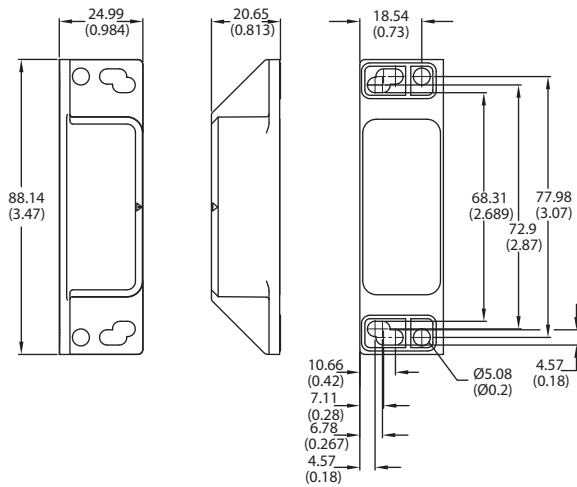

Nut Torque Specification

Switch/Actuators: 2.26 N·m (20 in·lb)

Minimum Distance Between Sensors

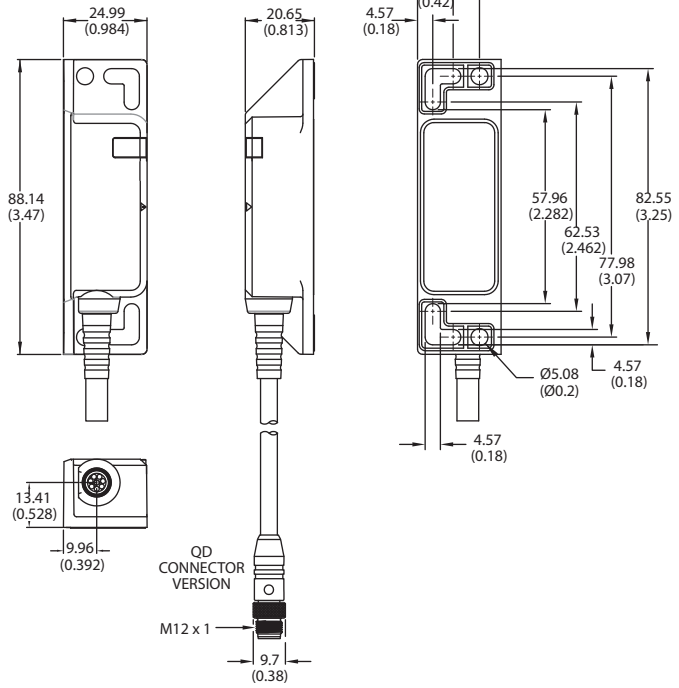
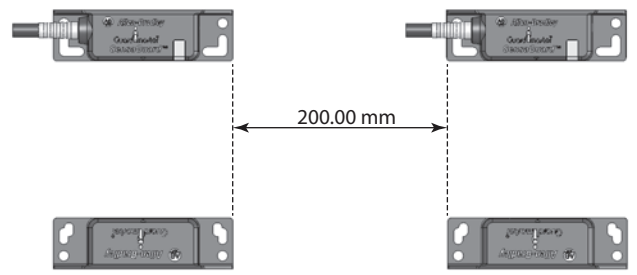

Mode of Operation

Status indicators:

- **“Status/Diag” LED illuminates green:** Door/guard closed, safety outputs active.
- **“Status/Diag” LED illuminates red:** Door/guard open, safety outputs off.
- **“Status/Diag” LED flashes red:** Unit failure. See Diagnostic section on page 3.
- **“Status/Diag” LED flashes green:** Safety inputs off.
- **“Status/Diag” LED flashes amber:** Sensor is approaching maximum sensing distance (-N and -N9 models only).

Mounting Information

To mount the switch and actuator, use nonremoveable means, e.g., epoxy, one-way screws, riveting, and welding unless the switch and actuator are installed to be hidden or shielded. See ISO 14119 for further information.

Do not over torque the mounting hardware.

Position the switch and actuator so they are aligned with each other.

Typically the actuator is mounted to the moveable/removeable guard, door, or gate. Keep the switch and actuator within the sensing range below.

Misalignment Curve

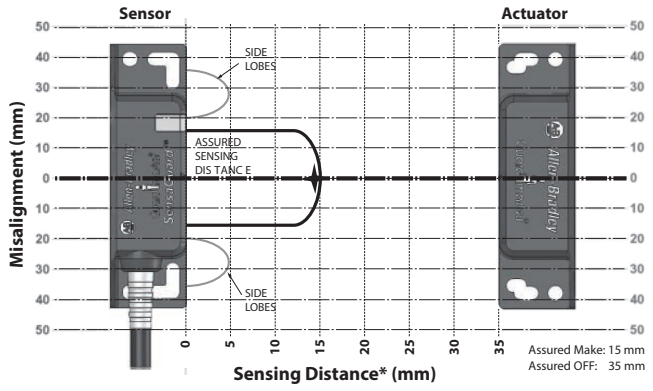

* When the actuator approaches the sensor in the x-direction or from above (z direction) and is misaligned in the y-direction.

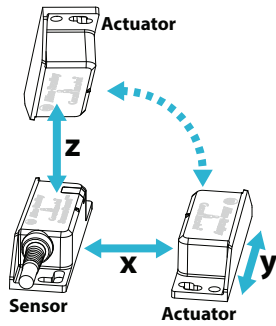

Recommended mating cable, 2 m (6.5 ft)—889D-F8AB-2.
 Replace the 2 with 5 (5 m) or 10 (10 m) for standard cable lengths.

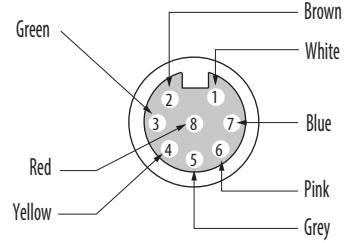

IMPORTANT Allow a minimum spacing of 9 mm (0.35 in.) if the actuator and sensor faces approach laterally (from the y-direction). This will prevent false triggering due to the side lobe areas.
 To ensure proper functioning of margin indication (non-safety), z-direction approach is not recommended for -N and -N9 models.

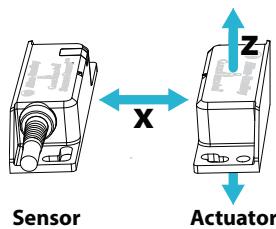
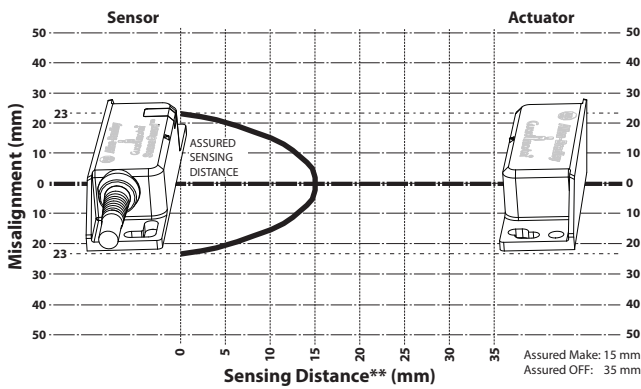

5-Pin Unit

Pin Number	Signal
1	+24V
2	OSSD 1
3	0V
4	OSSD 2
5	Aux.

Recommended cordset, 2m (6.5 ft) - 889D-F5AC-2. Replace the 2 with 5 (5 m) or 10 (10 m) for standard cable lengths.

Note: If the user does not require the Auxiliary signal, a 4-pin cordset (889D-F4AC-2) can be used.

Recommended patchcord for use with ArmorBlock® Guard Safety I/O, 2 m (6.5 ft) - 889D-F4ACDM-2. Replace the 2 with 0M3 (0.3 m), 1 (1 m), 5 (5 m), or 10 (10 m) for standard cable lengths.

Note: Do not use a 5-pin patchcord with the ArmorBlock.

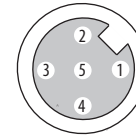

Wiring Diagram

8-Pin Unit

Pin Number	Wire Color	Signal
1	White	Aux. Outputs
2	Brown	+24V
3	Green	NA
4	Yellow	OSSD 2, +24V Input
5	Grey	OSSD 1
6	Pink	OSSD 2
7	Blue	0V
8	Red	OSSD 1, +24V Input

Diagnostic

Unit Indicators (per IEC 60073)

	State	Status	Troubleshooting
Device Output LED	Off	Not Powered	NA
	Red	Not Safe, OSSD not active	NA
	Green	Safe, OSSD active	NA
	Green Flash	Power up test or OSSD inputs not valid	Check 24V DC or OSSD inputs (yellow and red wire)
	Red Flash	1 Hz Flash Recoverable Fault 4 Hz Flash Non-recoverable Fault	Recoverable fault — check OSSD outputs are not shorted to GND, 24V DC or each other. Cycle power.
	Amber Flash (-N and -N9 models only)	1 Hz Flash margin indicator Safe, OSSD active	Sensor is reaching maximum sensing distance; re-align sensor with actuator

IMPORTANT Refer to Technical Specifications (page 1) for certification information and ratings.

Commissioning Power the Sensor

Connect the sensor to 24V DC. See "Typical Wiring Diagram" section for help.

IMPORTANT

The sensor "Status/Diag" LED will begin to blink Green eight times then repeat, indicating that the sensor has not yet learned an actuator.

The sensor can be commissioned to either have the ability to learn another actuator or be locked for a one time learn only. See "Teaching in the Actuator" section.

Teaching in the actuator (ability to learn an additional actuator)

Quick Start

1. Power up the sensor and bring an actuator into the sensing range.
2. Leave the actuator in the sensing field for two minutes or longer.
3. Learn is complete.

IMPORTANT

The sensor can learn a new actuator up to eight times. The "Status/Diag" LED will blink the number of actuators left that a sensor can learn.

Initially teaching in the actuator

The sensor will automatically start the learning process as soon as an actuator is brought into the sensing range.

IMPORTANT

The actuator must not be removed from the sensing field during the learning procedure or the ability to learn additional actuators will be disabled.

Learning Sequence

1. Target present: "Status/Diag" LED blinking Green 1 Hz rate
2. Verifying actuator: "Status/Diag" LED blinking Green/RED 1 Hz rate (15sec)
3. Program sensor: "Status/Diag" LED blinking Green/RED 4 Hz rate (15sec)
4. Program complete: "Status/Diag" LED blinking Green (# of learns left) (15 sec)
5. Ready state: "Status/Diag" LED solid Green
6. Learn is complete

IMPORTANT

A sensor can be locked so it can not learn another actuator; see teaching in the actuator (one time learn only) section.

Teaching in the Actuator (one time learn only; unit locked)

Initially teaching in the actuator

The sensor will automatically start the learning process as soon as an actuator is brought into the sensing range.

Learning Sequence

1. Target present: "Status/Diag" LED blinking Green 1 Hz rate
2. Verifying actuator: "Status/Diag" LED blinking Green/RED 1 Hz rate (15 sec)
3. Program Sensor: "Status/Diag" LED blinking Green/RED 4 Hz rate (15 sec)
4. Program Locking: "Status/Diag" LED blinking Green (# of learn left) (15 sec)

During the Program Locking Stage, perform the following steps:

- a. Remove the actuator from the sensing field, until the "Status/Diag" LED changes to solid red.
- b. Replace the actuator back into the sensing field and the "Status/Diag" LED will continue blinking green (number of learns remaining).

5. Ready state: "Status/Diag" LED solid green

6. Learn is complete

Learning a new actuator:

To learn a replacement actuator, bring the actuator to be taught into the sensing range of the safety switch.

The learn sequence is the same as the sequence for commissioning the first actuator.

IMPORTANT

A sensor can be locked so it can not learn another actuator. See "Teaching in the actuator (one time learn only; unit locked)" section above.

A sensor can not re-learn a previously learned actuator or a standard SensaGuard actuator.

The sensor will only recognize the most recently learned actuator.

Unique Coded Diagnostic:

Error codes for learning process. Repeat until the unit is power cycled.

Status/Diag LED—Flashes (4 Hz)	Error Code
Green	OSSD inputs not valid
Red-Red-Red-Green	Can not learn a standard SensaGuard Actuator
Red-Red-Red-Green-Green	Actuator already learned
Red-Red-Red-Green-Green-Green	Bad RFID; Target moved out of range
Red-Red-Red-Green-Green-Green-Green	Exceeded learning 8 actuators
Red-Red-Red-Green-Green-Green-Green-Green	Unit locked: Can not learn another actuator

Troubleshooting

Series Circuit

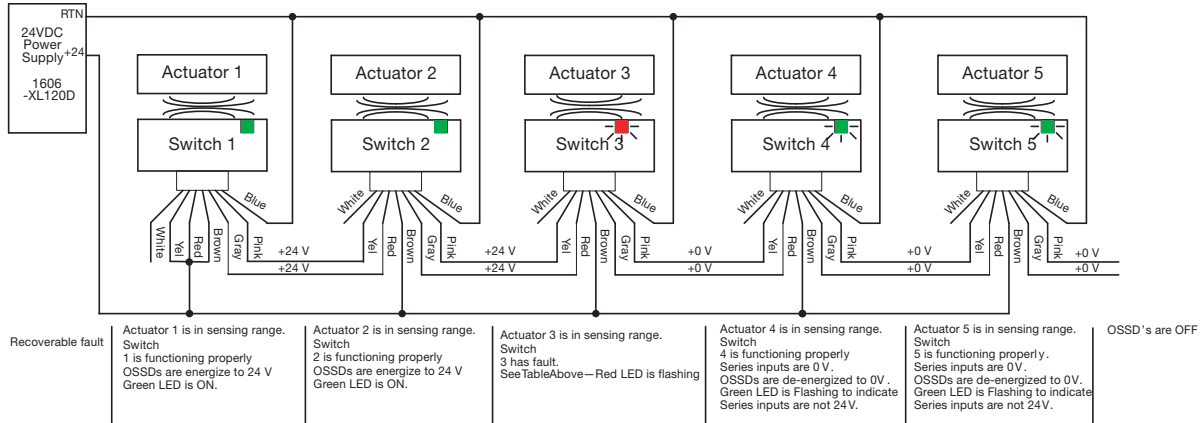

IMPORTANT

Refer to Technical Specifications (page 1) for certification information and ratings.

Unit Response Time (does not include safety control system response time)

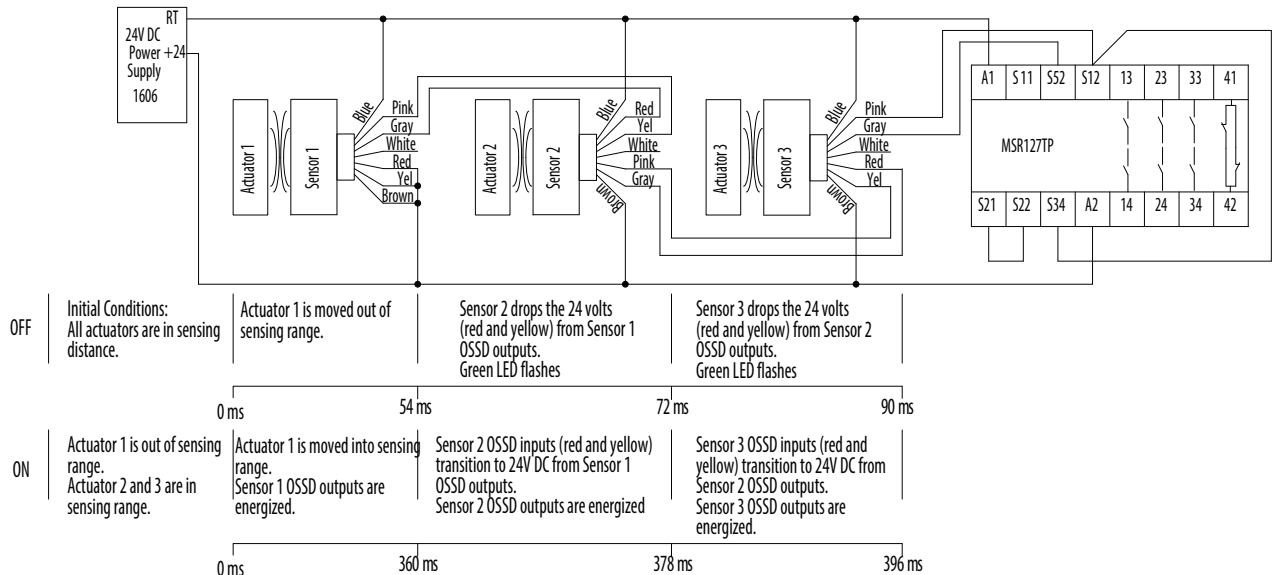

IMPORTANT

Refer to Technical Specifications (page 1) for certification information and ratings.

Application Wiring Examples

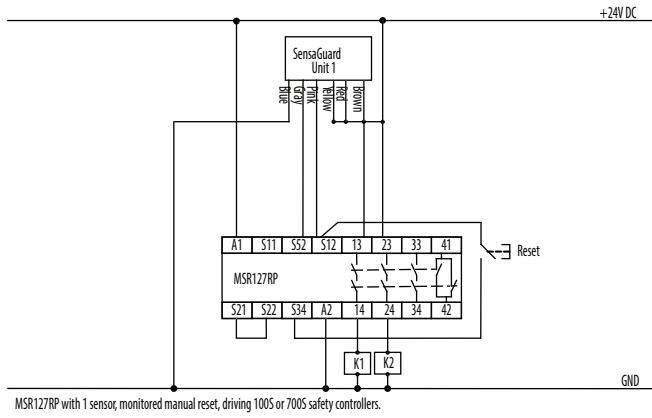

MSR127RP with 1 sensor, monitored manual reset, driving 100S or 700S safety controllers.

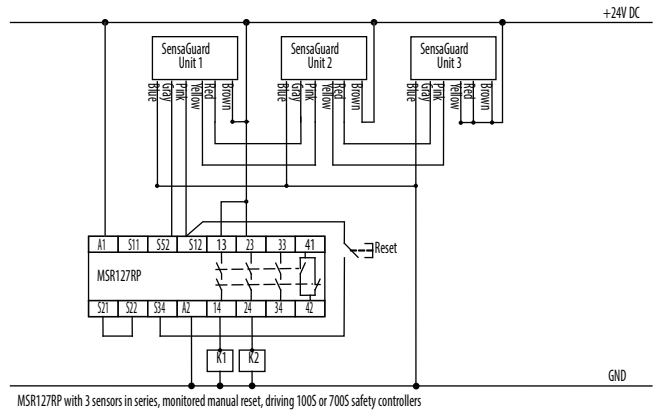

MSR127RP with 3 sensors in series, monitored manual reset, driving 100S or 700S safety controllers

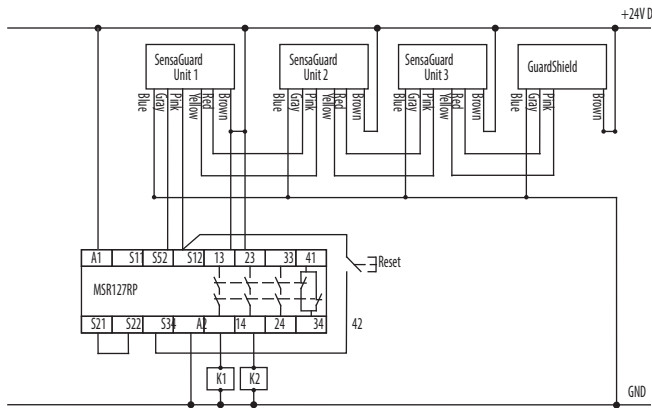

MSR127RP with 3 sensors and 1 440L light curtain in series, monitored manual reset, driving 100S or 700S safety relays.
Note: Light curtain must be last (farthest from MSR127).

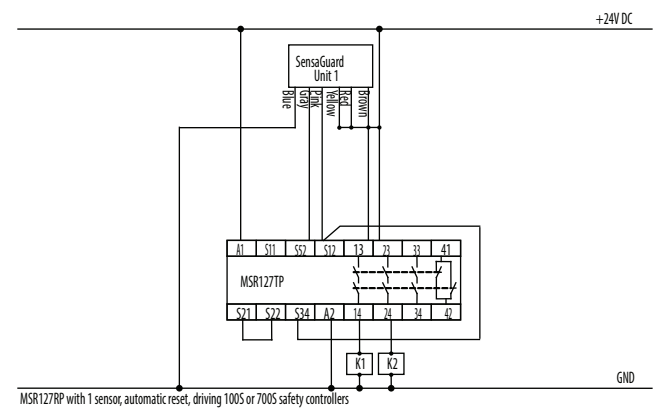

MSR127RP with 1 sensor, automatic reset, driving 100S or 700S safety controllers

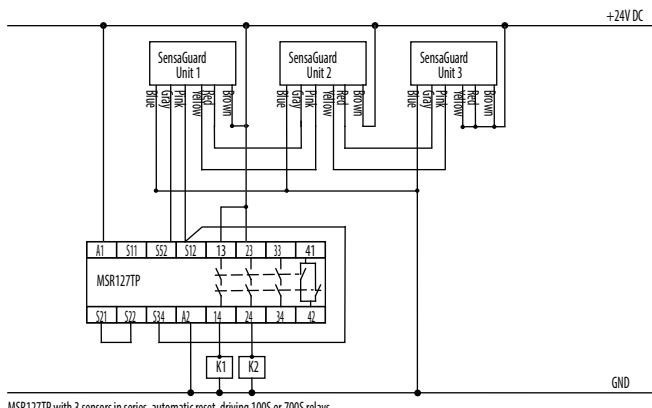

MSR127TP with 3 sensors in series, automatic reset, driving 100S or 700S relays.

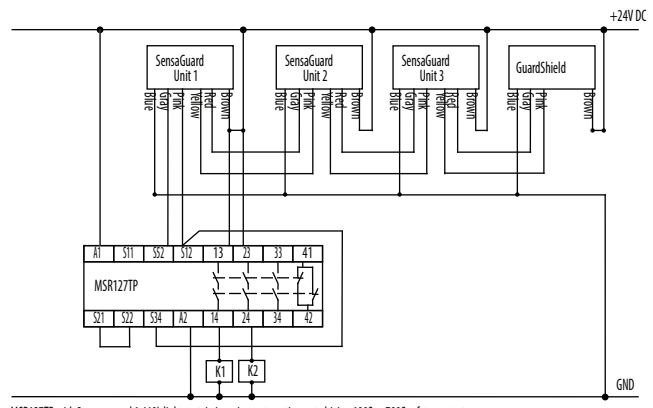

MSR127TP with 3 sensors and 1 440L light curtain in series, automatic reset, driving 100S or 700S safety contactors.
Note: Light curtain must be last (farthest from MSR127)

IMPORTANT

Refer to Technical Specifications (page 1) for certification information and ratings.

Application Wiring Examples

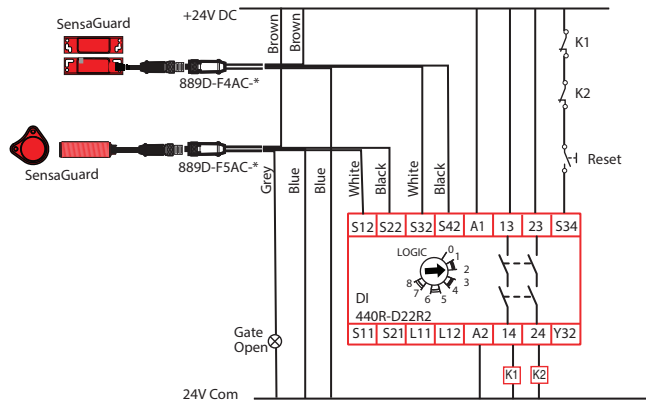

GSR DI with two 5-pin SensaGuards monitored manual reset driving 100S or 700S safety controllers

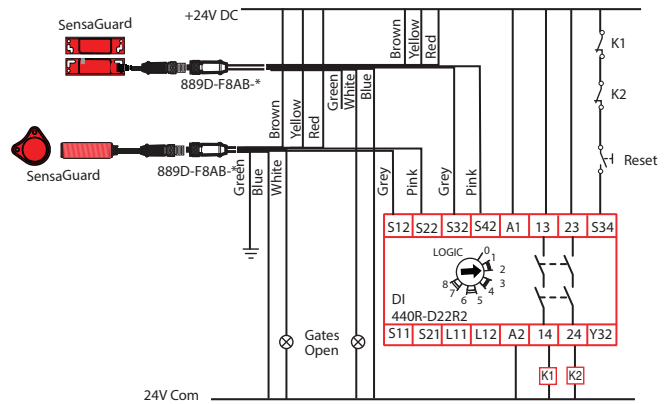

Note: The Green wire is connected to the housing of the Stainless Steel SensaGuard only; it has no connection for plastic SensaGuard.

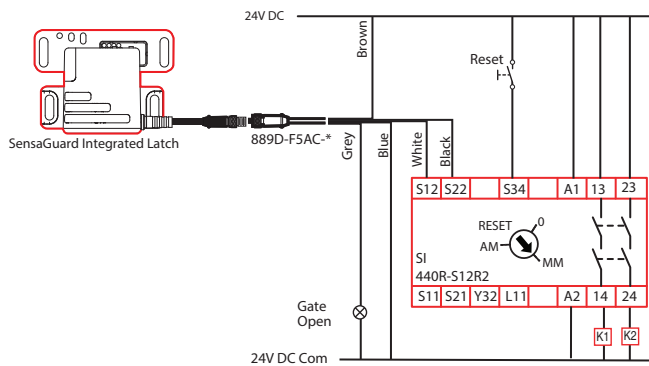

GSR SI with one 5-pin SensaGuard monitored manual reset driving 100S or 700S safety controllers

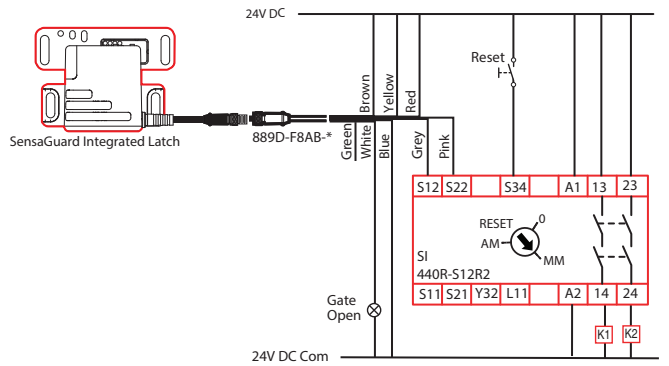

GSR SI with one 8-pin SensaGuards monitored manual reset driving 100S or 700S safety controllers

IMPORTANT

Refer to Technical Specifications (page 1) for certification information and ratings.

IMPORTANT

GSR DI with two 8-pin SensaGuards monitored manual reset driving 100S or 700S safety controllers

List of Recommended Safety Control Interfaces

GSR DI, GSR DIS, GSR SI, CR30, MSR126, MSR127, MSR131, MSR138, MSR211, MSR221, MSR121, MSR320, SmartGuard™, 1791DS/ES CompactBlock™ Guard Safety I/O, 1732DS/ES ArmorBlock Guard Safety I/O. Relay must have OSSD (light curtain) inputs.

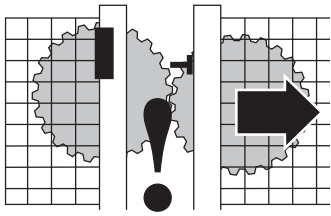

Check the machine is isolated and stopped whenever the interlocked guard door is open.

IMPORTANT: After installation and commissioning, the actuator, switch and switch lid fixing screws should be coated with tamper evident varnish or similar compound.

Maintenance

Monthly

Check the correct operation of the switching circuit. Also check for signs of abuse or tampering. Inspect the switch casing for damage.

Repair

If there is any malfunction or damage, no attempts at repair should be made. The unit should be replaced before machine operation is allowed.

Declaration of Conformity

This is to declare that the products shown in this document conform with the Essential Health and Safety Requirements (EHSRs) of the European Machinery Directive. These products also conform to EN 60947-5-3, EN ISO 14119, and have third-party approval.

For a comprehensive certificate please visit: www.ab.com/safety

Rockwell Automation maintains current product environmental information on its website at <http://www.rockwellautomation.com/rockwellautomation/about-us/sustainability-ethics/product-environmental-compliance.page>

Allen-Bradley and Rockwell Automation are trademarks of Rockwell Automation, Inc. Trademarks not belonging to Rockwell Automation are property of their respective companies.

www.rockwellautomation.com

Power, Control and Information Solutions Headquarters

Americas: Rockwell Automation, 1201 South Second Street, Milwaukee, WI 53204-2496 USA, Tel: (1) 414.382.2000, Fax: (1) 414.382.4444

Europe/Middle East/Africa: Rockwell Automation NV, Pegasus Park, De Kleetlaan 12a, 1831 Diegem, Belgium, Tel: (32) 2 663 0600, Fax: (32) 2 663 0640

Asia Pacific: Rockwell Automation, Level 14, Core F, Cyberport 3, 100 Cyberport Road, Hong Kong, Tel: (852) 2887 4788, Fax: (852) 2508 1846

Publication 440N-IN015A-EN-P—PN-243717—10000979531 Ver 00—February 2015
Copyright © 2015 Rockwell Automation, Inc. All rights reserved. Printed in the USA.